

INSTALLATION INSTRUCTIONS

Front Mount Door Handle

Part #: H42-FM

JACLO®

Confidence from start to finish.®

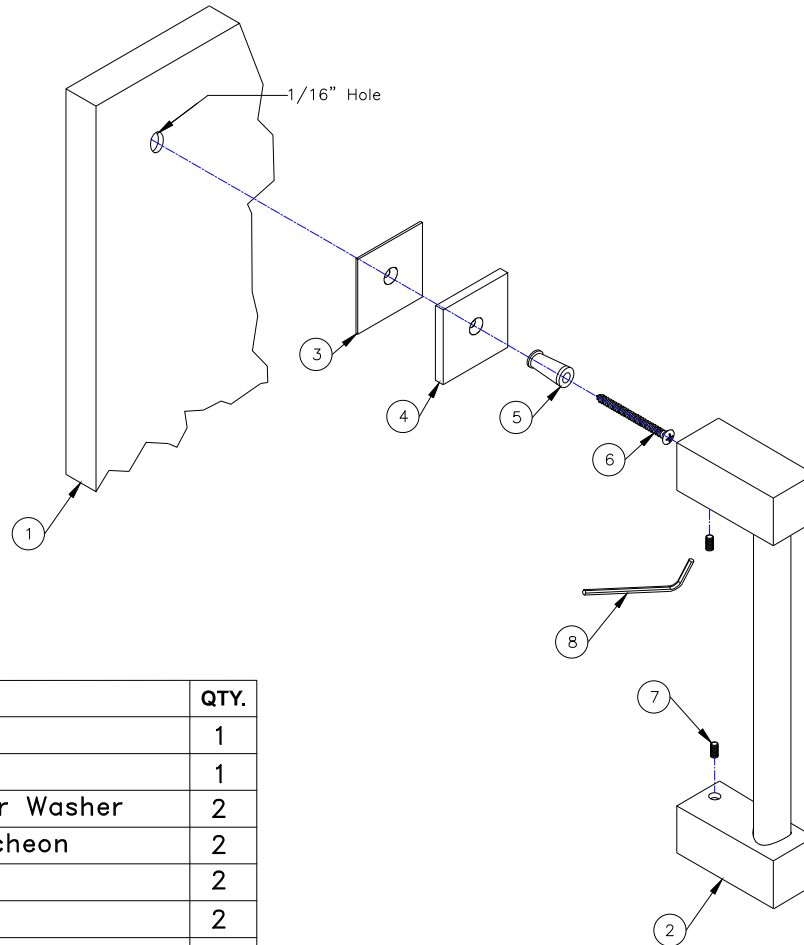

COMPONENT PARTS		QTY.
1	Wood Door	1
2	Door Handle	1
3	30817-1 SQ. Rubber Washer	2
4	CU-435-ESC. Escutcheon	2
5	Metal Sleeves	2
6	Screw 30817-4-0	2
7	Set Screws	2
8	Hex Wrench	1

1. Locate center to center dimension for drilling (handles are sold with cc measurement)
2. Drill 1/16" hole top and bottom
3. Start at top hole
4. Insert wood screw (6) through sleeve (5), through escutcheon (4), through washer (if needed) and screw into wood door
5. Bottom hole, repeat step 4
6. Attach door pull to sleeve with set screw

INSTALLATION INSTRUCTIONS

Back to Back Door Handle

Part #: H42-BB

JACLO®

Confidence from start to finish.®

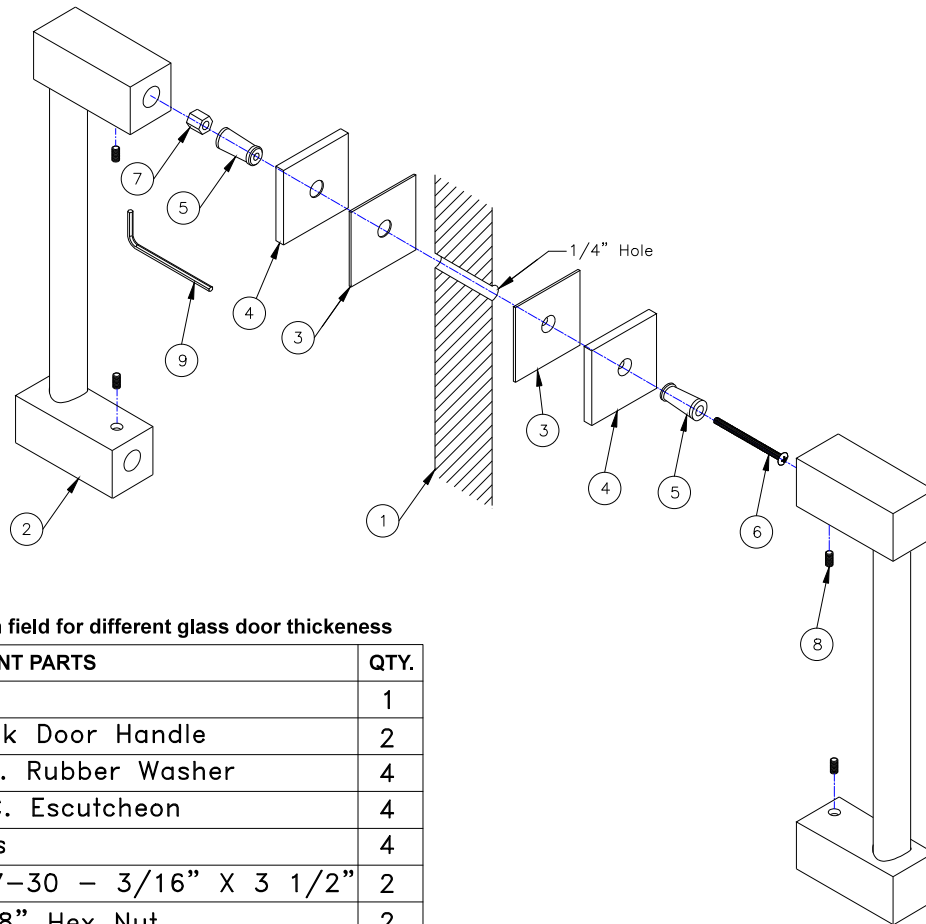

*Screw is able to be cut in field for different glass door thickness

COMPONENT PARTS		QTY.
1	Glass Door	1
2	Back-to-Back Door Handle	2
3	30817-1 SQ. Rubber Washer	4
4	CU-435-ESC. Escutcheon	4
5	Metal Sleeves	4
6	*Screw 30817-30 - 3/16" X 3 1/2"	2
7	5/16" X 3/8" Hex Nut	2
8	Set Screws	4
9	Hex Wrench	1

1. Locate center to center dimension for drilling (handles are sold with cc measurement)
2. Drill 1/4" hole top and bottom
3. Start at top hole
4. Insert screw (6) through sleeve (5), through escutcheon (4), through washer (3), through door, through washer (3), through escutcheon (4), through sleeve and attach with hex nut.

Please note, screw is able to be cut in field for different glass door thickness

5. Bottom hole, repeat step 4
6. Attach door pulls to sleeves with set screw

INSTALLATION INSTRUCTIONS

Front Mount Door Handle with Glass Mounting Kit Part #: H42-FM with H42-GLSKIT

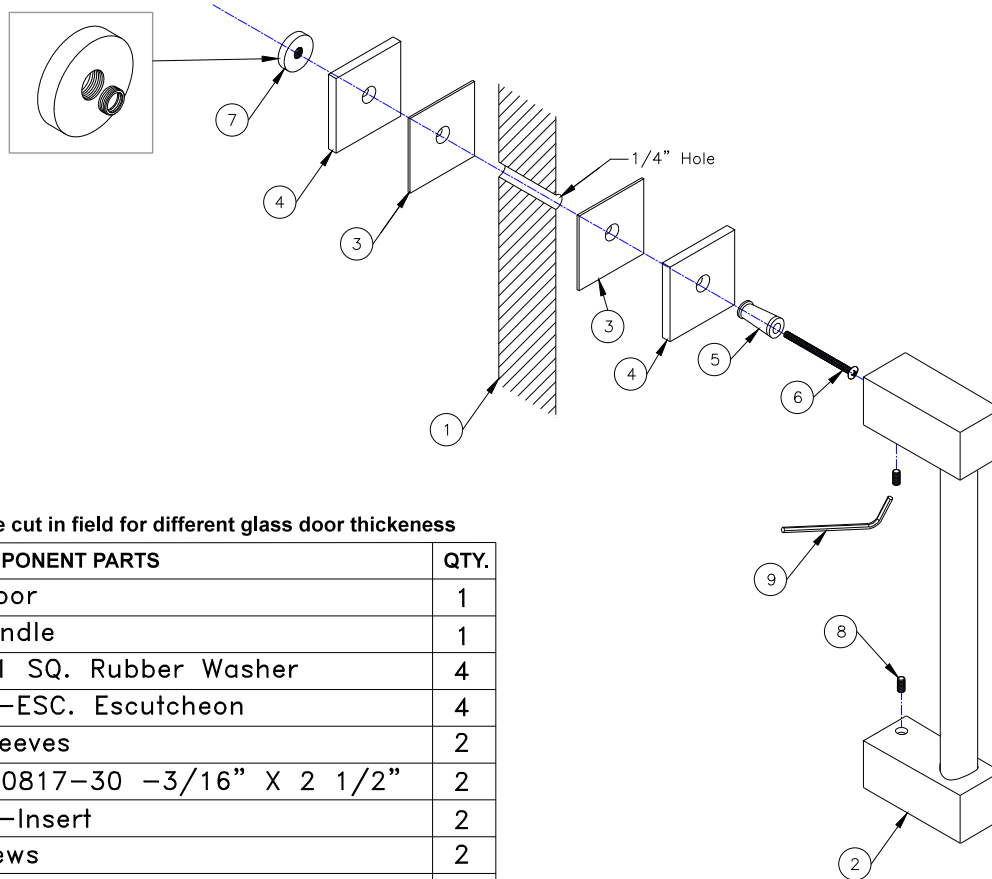

*Screw is able to be cut in field for different glass door thickness

	COMPONENT PARTS	QTY.
1	Glass Door	1
2	Door Handle	1
3	30817-1 SQ. Rubber Washer	4
4	CU-435-ESC. Escutcheon	4
5	Metal Sleeves	2
6	*Screw 30817-30 -3/16" X 2 1/2"	2
7	Glass-B-Insert	2
8	Set Screws	2
9	Hex Wrench	1

1. Locate center to center dimension for drilling (handles are sold with cc measurement)
2. Drill 1/4" hole top and bottom
3. Start at top hole
4. Insert screw (6) through sleeve (5), through escutcheon (4), through washer (3), through door, through washer (3), through escutcheon (4) and secure to glass kit (pre-assembled)

Please note, screw is able to be cut in field for different glass door thickness

5. Bottom hole, repeat step 4

To learn more about JACLO's warranty, please visit [**jaclo.com**](http://jaclo.com)