

INSTALLATION INSTRUCTIONS

Extension for Cycling Valve

Part #: J-DIV-CSV-EXT-C, J-DIV-CSV-EXT-T



J-DIV-CSV-EXT-C-



J-DIV-CSV-EXT-T-

PARTS

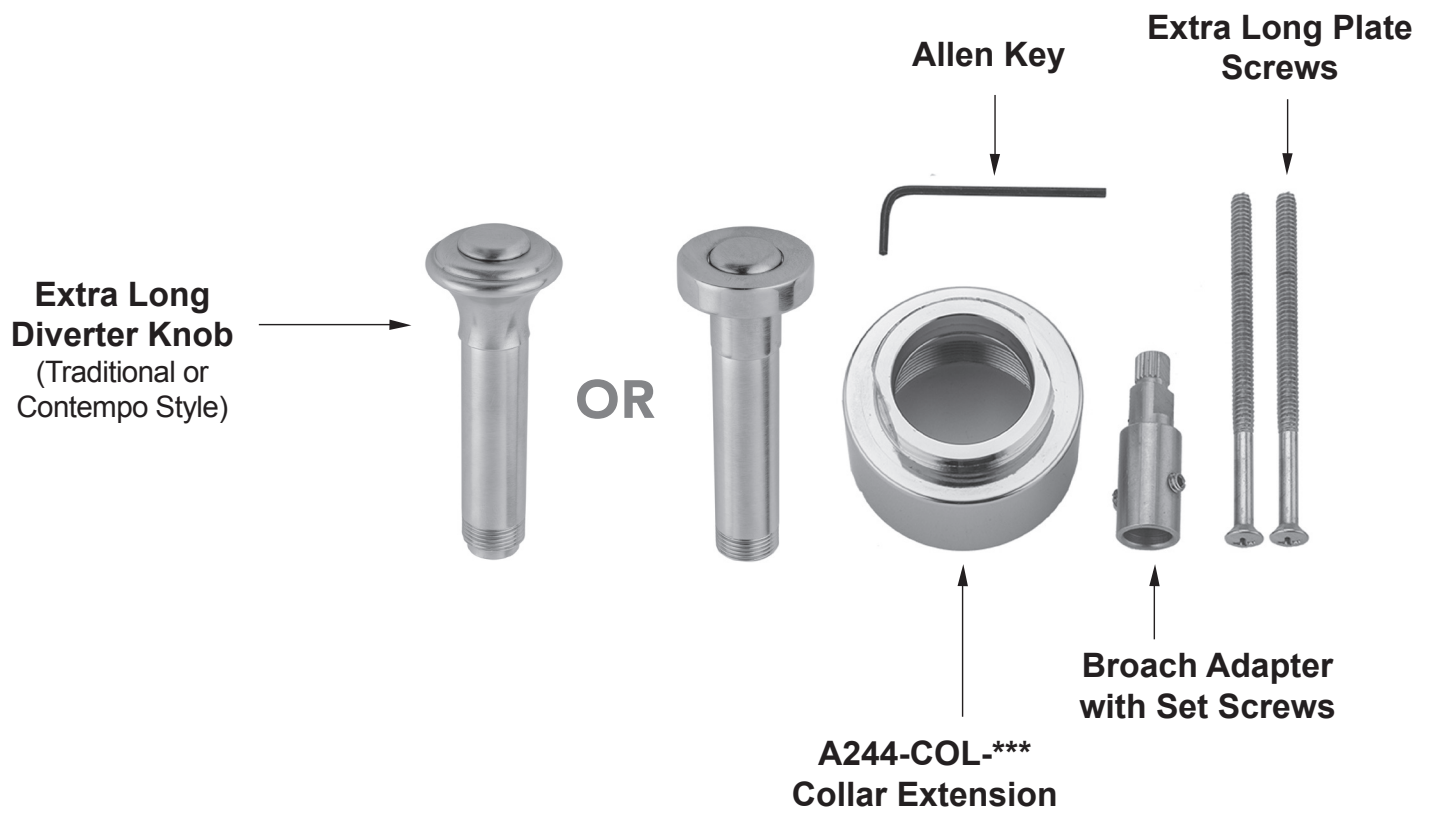

PREPARATION

1. Remove Decorative Handle (5) & Trim Plate (10)
2. Remove Decorative Cap (4) if present

****NOTE: NOT ALL CSV'S HAVE A CAP THAT GOES OVER COLLAR****

INSTALLATION

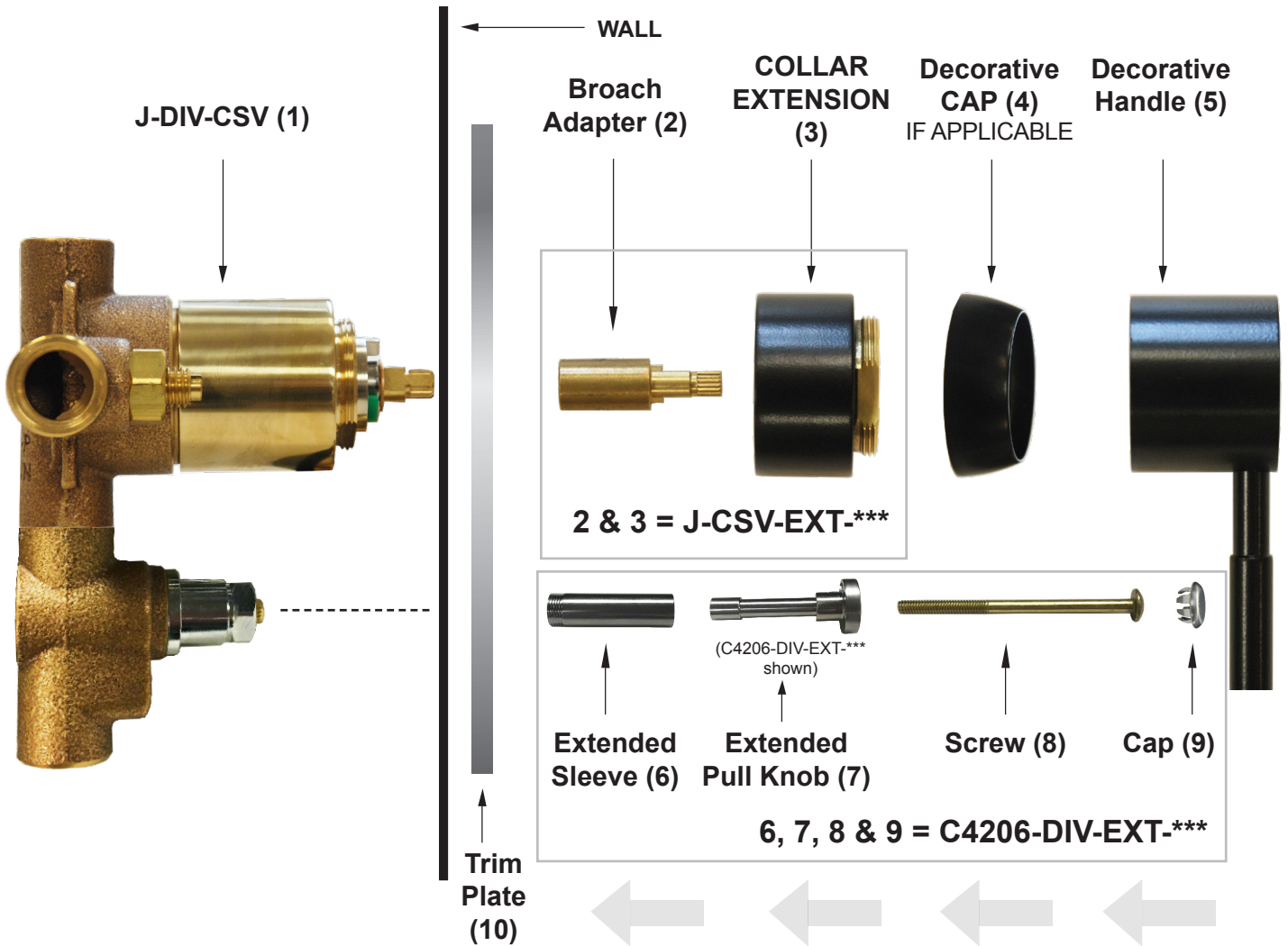

PICTURE FOR REFERENCE ONLY

1. Attach Broach Adapter (2) to J-DIV-CSV stem. Tighten set screws on Broach Adapter.
2. Thread on Collar Extension (3) to existing collar on valve.
3. Replace Decorative Cap (4), (if needed)
4. Attach Existing Decorative Handle (5) by tightening set screw in handle to Broach Adapter (2)
5. Thread Extended Sleeve (6) to lower portion of valve
6. Install Extended Pull Knob (7) through Extended Sleeve (6) to broach
7. Push Screw (8) through Extend Pull Knob (7) & hand tighten
8. Attach Cap (9) to extended Pull Knob (7)

To learn more about JACLO's warranty, please visit [**jaclo.com**](http://jaclo.com)