

Pressure Balance Valve

Model #: J-PBV

FEATURES:

- Pressure balance valve mixes hot & cold water
- Anti-scald protection
- Moving lever up and down controls the volume of water and turns water on and off
- Rotating the handle left and right controls the water temperature
- Ceramic cartridge
- 1/2" NPT female ports
- 5.2 GPM flow @ 60 PSI
- Works well with low water pressure
- New and improved one piece cartridge for ease of installation
- Extension kit NOT AVAILABLE for this rough valve. Please be sure to review install instructions for proper install depth from finished wall.

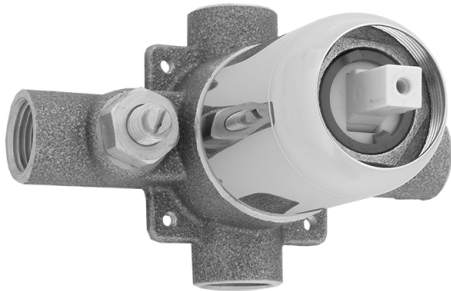

AVAILABLE FINISHES:

N/A

SPECIFICATION DRAWING:

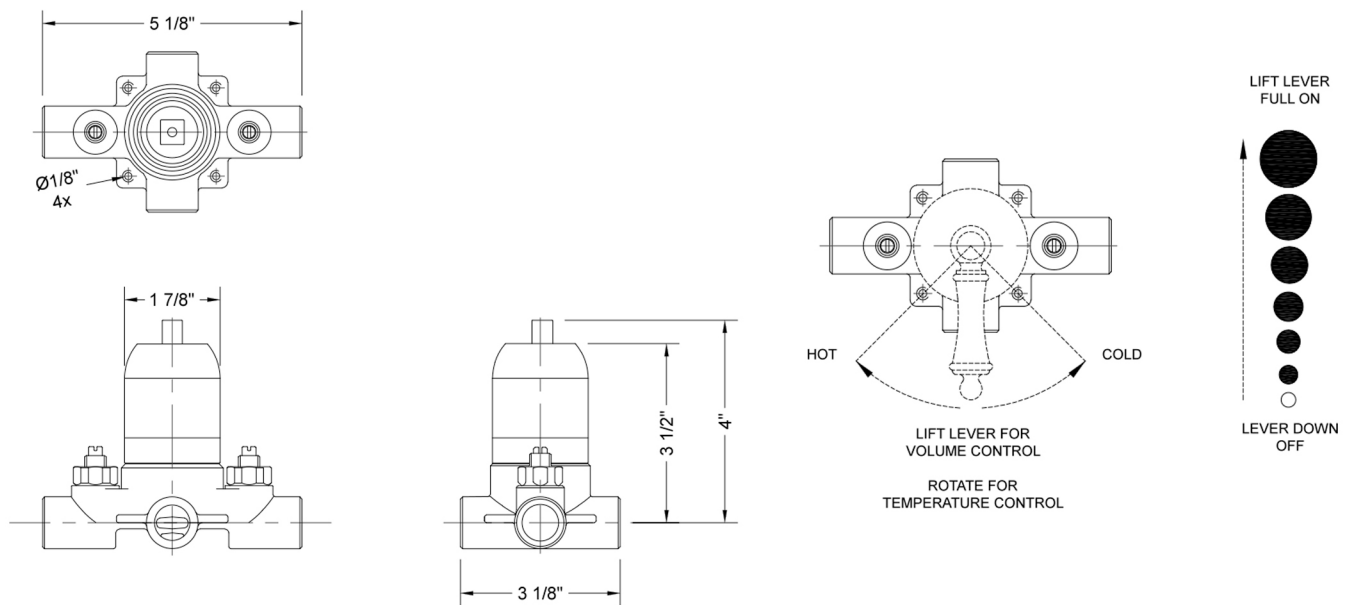

COMPLIANCES:



Complies with: ASME A112.18.1-2012/CSA B125.1-12